

CARBON SEATPOST INSTALLATION GUIDE

RITCHEY[®]

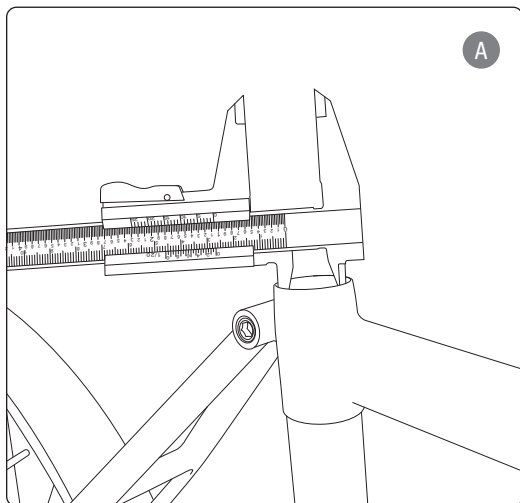

STEP 1: (Figure A)

Measure seat tube diameter with a caliper to ensure it matches that of the frame specification. Installing a seatpost with an incorrect diameter will damage the seatpost and frame.

STEP 2:

Ensure the seat tube and binder/collar/clamp are free from burrs, sharp edges, corrosion and dirt.

STEP 3:

Apply a light layer of Carbon Assembly Paste onto the seatpost and inside the seat tube.

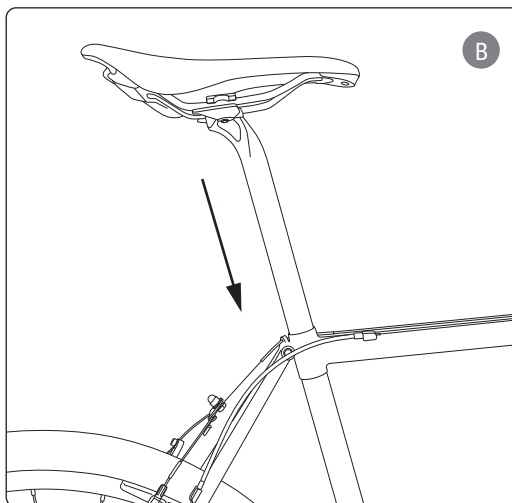

STEP 4: (Figure B)

Insert the seatpost into the seat tube **WITHOUT** twisting or rotating it. Twisting can scratch the carbon and create a stress point that can cause the seatpost to crack or break unexpectedly, resulting in an accident, damage to the bicycle, injury, or death. Ensure the minimum insertion length indication on the seatpost shaft (MIN[^]INSERT) is **BELOW** the top of seat tube.

STEP 5: (Figure C)

Tighten the seatpost clamp to the manufacturer-recommended torque value for the frame/set binder. However, do not exceed 6Nm for Ritchey carbon seatpost (7Nm max for carbon seatpost installed on Ritchey steel frames). Do not over-tighten the seatpost clamp, as doing so will damage the seatpost or frame.

